



# SIDENER ENGINEERING

A DIVISION OF EXOTIC AUTOMATION & SUPPLY

## CREI 05 B1 Specification Sheet

Sidener's Energy Isolation Valve functions as a two position 3-way hydraulic valve with redundant valving elements and redundant monitoring. The purpose of the valve is to, when energized, provide a flow path for a flow of hydraulic fluid from its source to the hydraulic system. When de-energized, the valve blocks flow from the hydraulic energy source and vents the hydraulic system to tank.

- ◇ The valve's hydraulic circuitry features a series flow condition from the inlet of the valve through redundant valving elements to the discharge of the valve.
- ◇ The hydraulic circuitry also features a parallel flow condition from the discharge of the valve through either or both of the valving elements to the tank port. This configuration assures that if a valving element fails to operate as requested, inlet flow will be blocked and fluid from the outlet side of the valve is directed to tank.
- ◇ Inductive Monitoring Switches indicate the movement of the redundant valving elements. Operation of the Inductive Monitoring Switches is typically monitored by a Safety Relay or a Safety PLC supplied by others.



**Contact us for  
Additional Assistance!**

## Specifications

<b>Maximum Rated Pressure</b>	Steel: P,A,B-5000 PSI T: 3000 PSI, Aluminum: P,A,B,T-3000PSI
<b>Operating Voltage Tolerance</b>	+/- 10%
<b>Amps Draw</b>	24VDC - 1.5 Amps
<b>Duty Cycle</b>	Continuous at 100% Voltage
<b>Step Response Time at 95%</b>	Energized:105ms ; De-energized: 85ms
<b>Operating Temperature</b>	-4 to 160 degrees Fahrenheit
<b>Fluid Compatibility</b>	Hydraulic Fluid according to DIN 51524
<b>Recommended Viscosity</b>	30 - 80 cSt
<b>Shift limit at 40 cSt</b>	150 l/min at rated pressure
<b>Filtration</b>	18/16/13 per ISO 4406 (1999)
<b>Approximate Weight</b>	Ductile - 49 pounds Aluminum - 34 pounds
<b>Mounting Orientation</b>	Unrestricted, Horizontal Preferred
<b>Electrical Connector-Cable Kit</b>	CREI-B1-WK: Kit contains 2 solenoid cable assemblies and 2 inductive position sensor cable assemblies, 10m long.



# CREI 05 B1 Specification Sheet

## Connection Drawing

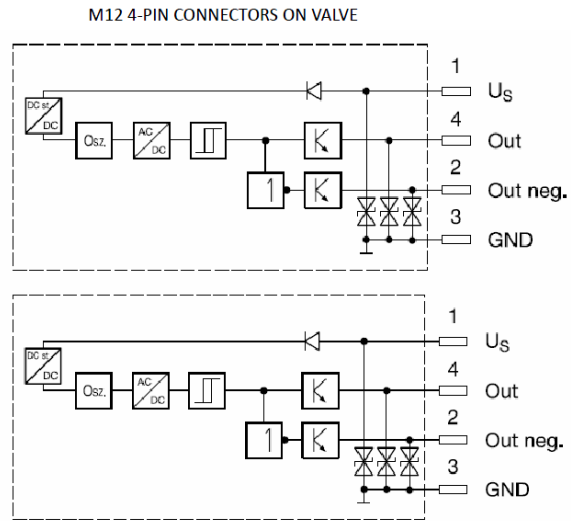
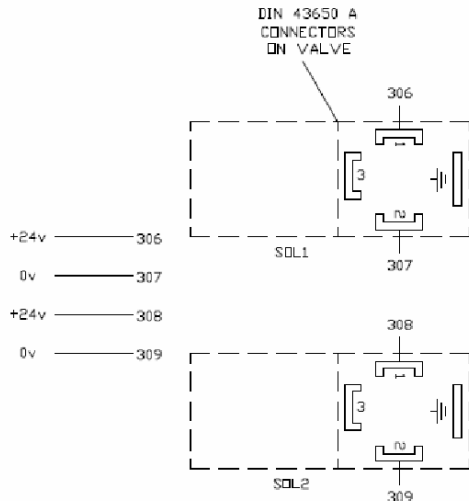

## Dimensional Drawing

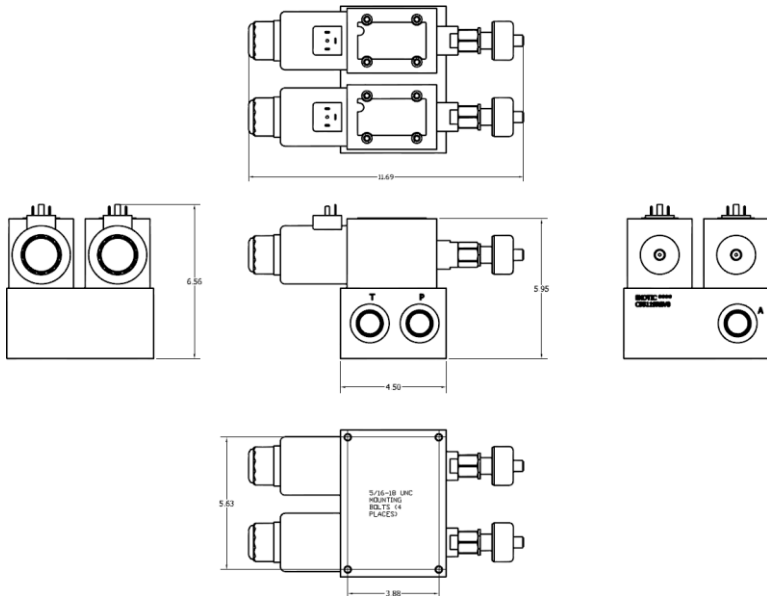

## Simplified CREI Circuit

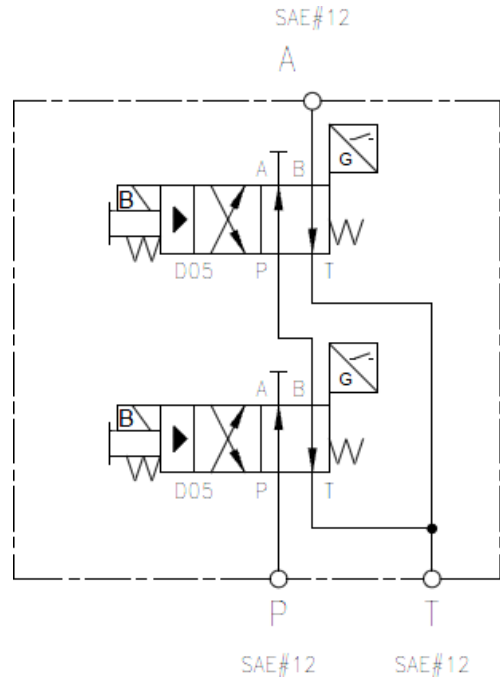

## Flow/Performance Curve

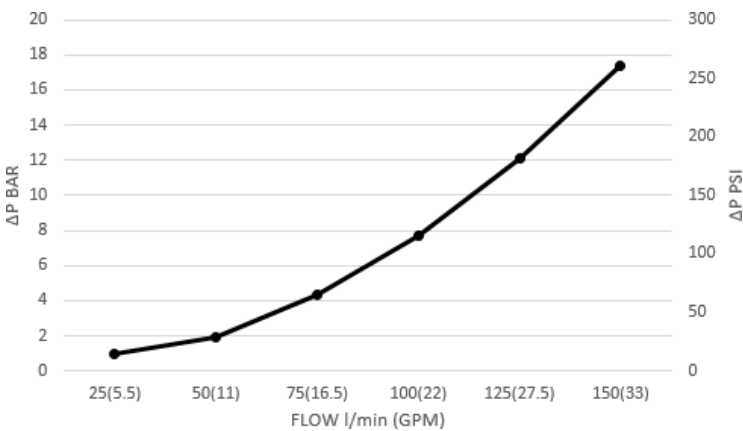

Sidener Engineering  
17450 Bataan Ct.  
Noblesville, IN 46062  
(317) 773-8119  
[indysales@erpc.com](mailto:indysales@erpc.com)  
[www.sidenereng.com](http://www.sidenereng.com)

