



SIDENER ENGINEERING

A DIVISION OF EXOTIC AUTOMATION & SUPPLY

CREI 03 B1 Specification Sheet

Sidener's Energy Isolation Valve functions as a two position 3-way hydraulic valve with redundant valving elements and redundant monitoring. The purpose of the valve is to, when energized, provide a flow path for a flow of hydraulic fluid from its source to the hydraulic system. When de-energized, the valve blocks flow from the hydraulic energy source and vents the hydraulic system to tank.

- ◇ The valve's hydraulic circuitry features a series flow condition from the inlet of the valve through redundant valving elements to the discharge of the valve.
- ◇ The hydraulic circuitry also features a parallel flow condition from the discharge of the valve through either or both of the valving elements to the tank port. This configuration assures that if a valving element fails to operate as requested, inlet flow will be blocked and fluid from the outlet side of the valve is directed to tank.
- ◇ Inductive Monitoring Switches indicate the movement of the redundant valving elements. Operation of the Inductive Monitoring Switches is typically monitored by a Safety Relay or a Safety PLC supplied by others.

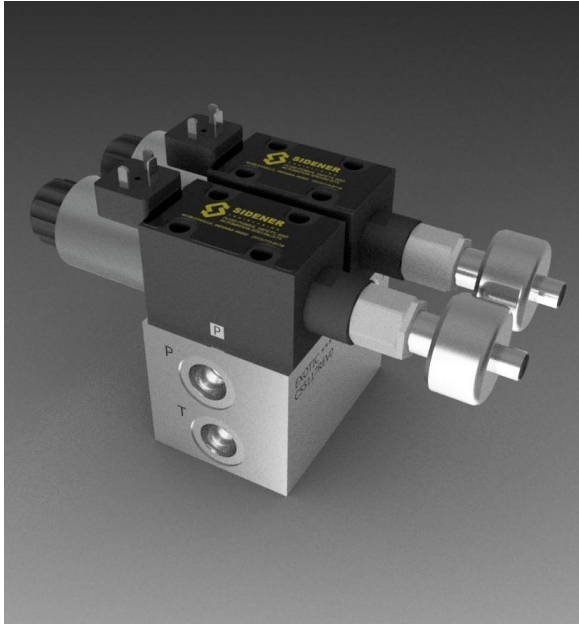

**Contact us for
Additional Assistance!**

Specifications

Maximum Rated Pressure	Steel: P,A,B-5000 PSI T: 3000 PSI, Aluminum: P,A,B,T-3000PSI
Operating Voltage Tolerance	+/- 10%
Amps Draw	24VDC - 1.29 Amps
Duty Cycle	Continuous at 100% Voltage
Step Response Time at 95%	Energized: 32ms ; De-energized: 40ms
Operating Temperature	-4 to 160 degrees Fahrenheit
Fluid Compatibility	Hydraulic Fluid according to DIN 51524
Recommended Viscosity	30 - 80 cSt
Shift limit at 40 cSt	70 l/min at rated pressure
Filtration	18/16/13 per ISO 4406 (1999)
Approximate Weight	Ductile - 21 pounds / Aluminum - 13 pounds
Mounting Orientation	Unrestricted, Horizontal Preferred
Electrical Connector-Cable Kit	CREI-B1-WK: Kit contains 2 solenoid cable assemblies and 2 inductive position sensor cable assemblies, 10m long.

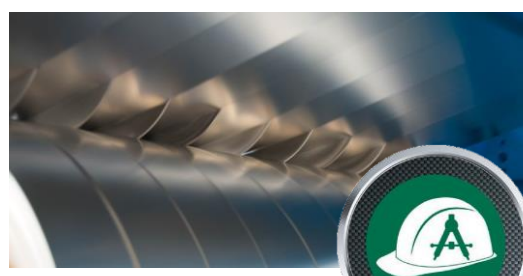

CREI 03 B1 Specification Sheet

Connection Drawing

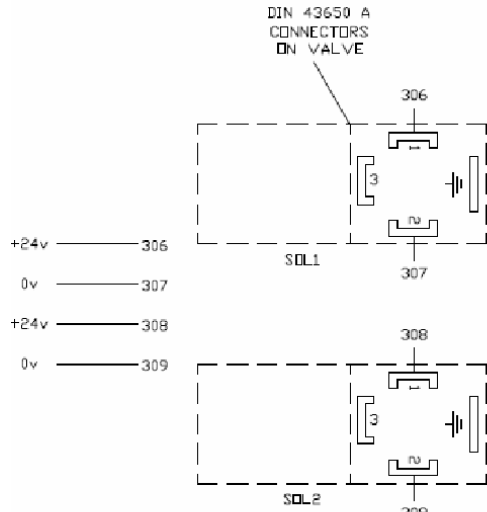

M12 4-PIN CONNECTORS ON VALVE

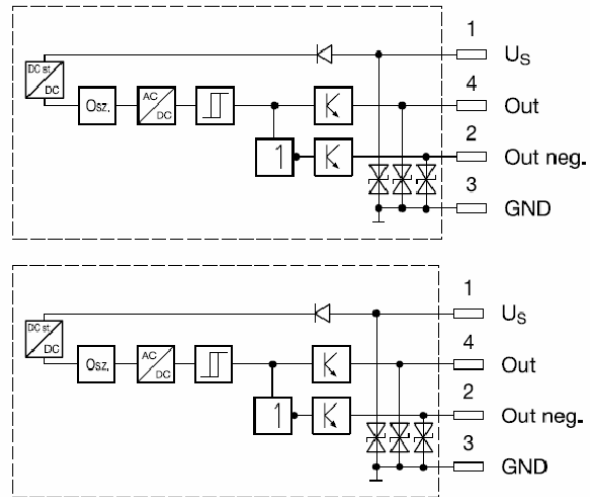

Dimensional Drawing

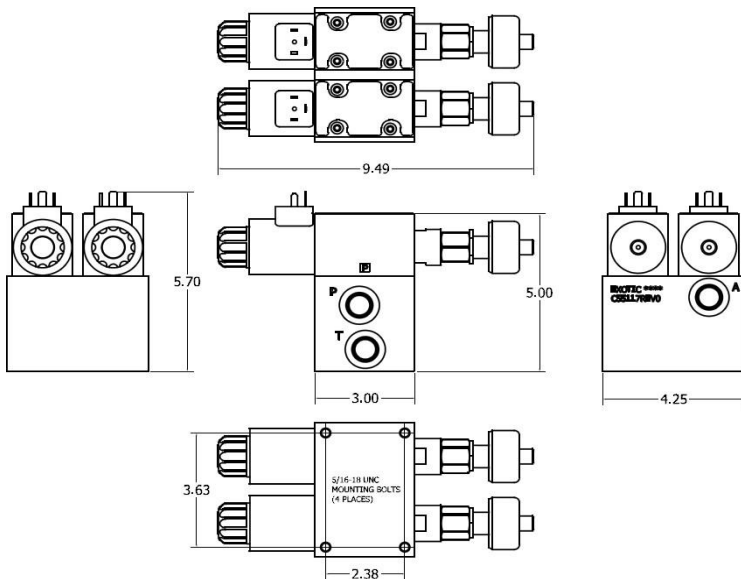

Simplified CREI Circuit

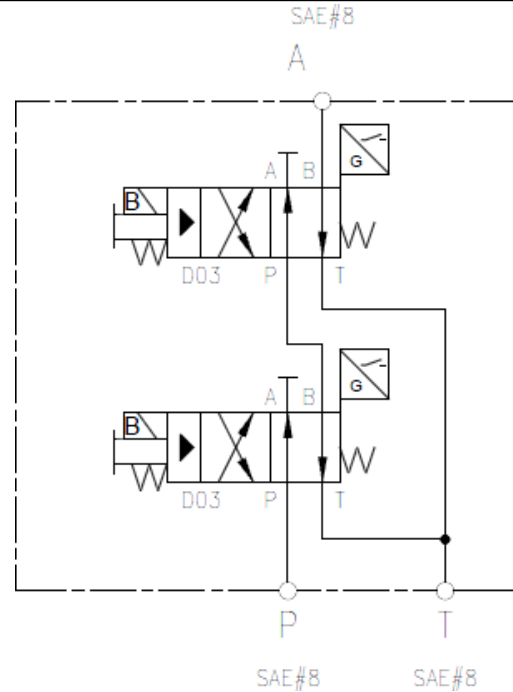

Flow/Performance Curve

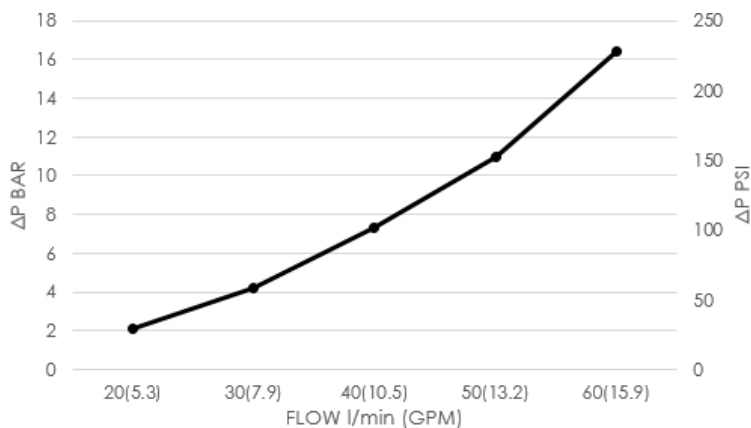

Sidener Engineering
17450 Bataan Ct.
Noblesville, IN 46062
(317) 773-8119

indsales@erpc.com
www.sidenereng.com

